



Global Traders: Operators of the Unconventional Inventory Liquidation Marketplace [FreeWorldImports.com](https://freeworldimports.com)

---

# NON-AUCTION COMMODITIES | EQUIPMENT | PRODUCTS

## OEM

# 3D HOLOGRAM CABINETS AND ASSOCIATED HOLOGRAPHIC APPLICATIONS

## INVENTORY – CIRCA 2023

---

309 Fellowship Road | East Gate Center | Suite 200 | Mt. Laurel | NJ 08054

Web-Presence: <http://freeworldbrand.com> | Liquidation Marketplace: <https://freeworldimports.com>

Commodities Webstore: <https://commodities.freeworldbrand.com/>

Phone/Fax: 609-256-9162 | Email: [bizdev@freeworldbrand.com](mailto:bizdev@freeworldbrand.com)



Global Traders: Operators of the Unconventional Inventory Liquidation Marketplace FreeWorldImports.com

---

## TRANSACTION / DEAL STRUCTURE

- *Ready for immediate delivery*
- **DELIVERY:** EXW, East Coast, USA Warehouse | FOB, China | DDP Customer loading dock
- **QUANTITY :** 4 Units | One Lot | One Deal
- **FWB Discounted Price :** [Contact Us](#) (PER UNIT)

### HOLOGRAM CABINETS TYPES

- **NO TOUCH (Android OS Enabled Cabinets):** 21.5 Inches | 32 Inches | 43 inches | 49 Inches | 55 Inches | 65 Inches | 75 Inches | 86 Inches | 98 Inches
- **INFRARED TOUCH (Android OS Enabled Cabinets):** 21.5 Inches | 32 Inches | 43 inches | 49 Inches | 55 Inches | 65 Inches | 75 Inches | 86 Inches | 98 Inches

### SUPPORTING INFORMATION

These hologram cabinets allow you to create an immersive virtual reality experience. Users are able to fully immerse themselves in the provided experience and enjoy realistic visual and auditory sensation. Each cabinet boast the following;

- Provide you with the resources that will enable you to create, publish and maintain locally shared and cloud-based holographic visual experiences.
- Built-in dual camera (Communication +AI)
- 5G + WIFI-6
- Built-in Computing capability
- Out-of-the-box holographic software
- Out-of-the-box phantom holographic cloud service

Interested parties are encouraged to contact us via email: [bizdev@freeworldbrand.com](mailto:bizdev@freeworldbrand.com)

**NOTE: Principals Only.**

**IMAGES AND OTHER RELATED INFORMATION APPEAR ON THE FOLLOWING PAGES**

---

309 Fellowship Road | East Gate Center | Suite 200 | Mt. Laurel | NJ 08054

Web-Presence: <http://freeworldbrand.com> | Liquidation Marketplace: <https://freeworldimports.com>

Commodities Webstore: <https://commodities.freeworldbrand.com/>

Phone/Fax: 609-256-9162 | Email: [bizdev@freeworldbrand.com](mailto:bizdev@freeworldbrand.com)

# Product introduction

3D hologram cabinet is a transparent optical film technology, through the dual combination of external box backlight source technology, to achieve the high-definition transparent display of the LCD screen.

3D hologram cabinet, standby state is a black screen, power state is a transparent display, similar to transparent glass, when the signal input, more perfect high-definition video signals, pictures, music; At the same time, you can clearly see the items placed behind the display.

Digital twin hologram cabinet can truly restore the three-dimensional effect of human cargo body. The experienter does not need to wear 3D glasses and other related equipment, but only needs to stand in a fixed shooting area, and can restore lifelike high-definition human images in equal proportions in the hologram cabin through acquisition equipment and processing, so that the experienter can immersive, and interact with their digital twins.



# Product advantage

Immersive experience: The hologram cabinet creates an immersive virtual reality experience. Allow users to fully immerse themselves in the experience and enjoy realistic visual and auditory sensations



## Product advantage



Interactivity and real-time feedback: The hologram supports users to interact with the virtual environment in real time, and through gestures, voice and head tracking technologies, users can freely interact with virtual objects and get real-time feedback.

# Product advantage

Creativity and display: The hologram provides a platform for designers, artists and creators to create and display, stimulate creativity, break creative limits, and present unique visual effects



# Software function specification

- 1、 Add infinite different scenes.
- 2、 Support scene preview mode Touch screen slide in the program or in the audience expansion screen to select the scene.
- 3、 Video (including transparent channel mov video), pictures, text and other input sources can be added.
- 4、 Achieve fast playback after recording.
- 5、 Support ARTC low latency push protocol (including remote low latency player), and support rtmp protocol.
- 6、 Supports input 4K and output 4K resolution video.





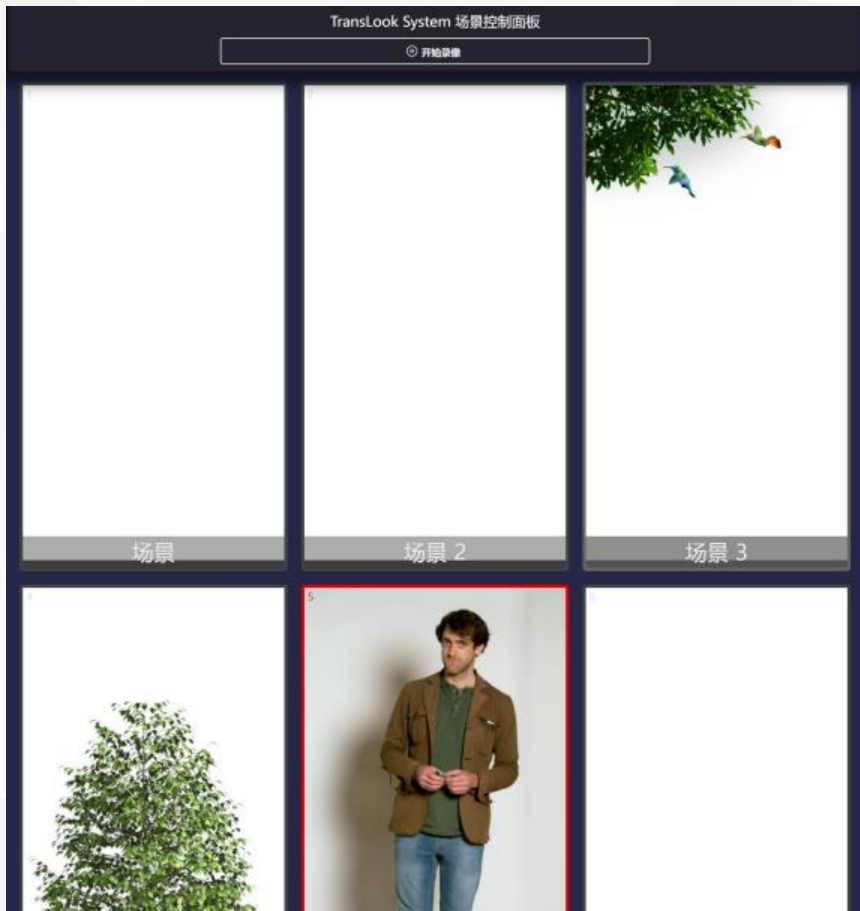

## V2.5.3 Update

1. Added sidebar for manipulating material and exporting it to different screens
2. Add the ability to display 3D models online, which can be connected to sketchfab, etc., and then add the ability to import models offline
3. Adjust the TAB style
4. Control panel adds video recording function
5. Reduce scene preview resource consumption
6. Output is adjusted to the default 4k resolution



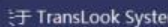
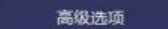
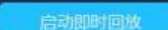
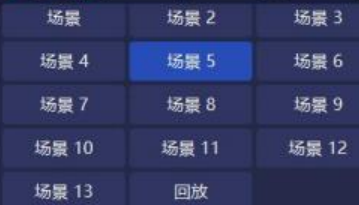

推流时间: 00:00:00 | 录像时间: 00:00:00 | 当前CPU负载: 10.0%

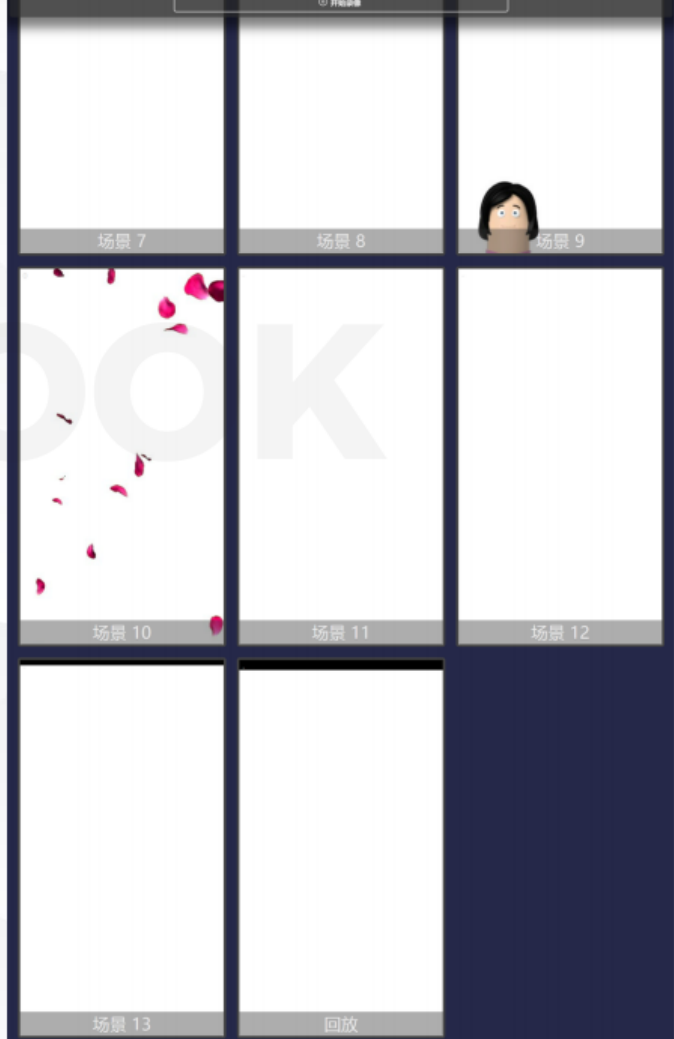
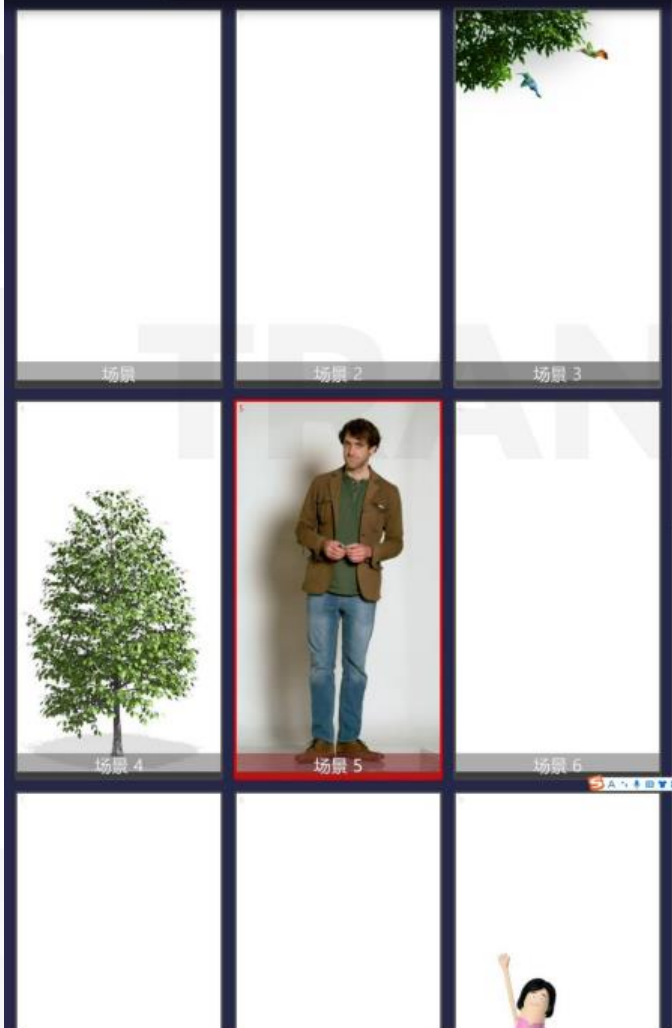

## Product specification

### Infrared touch intelligent operation

With infrared 10-point touch, accurate touch, switch multimedia content can be directly clicked on the screen for operation, convenient intelligence



### Infrared touch parameter

Touch technology	10 point infrared touch screen	Operating voltage	5.0V (Internal voltage3.3V)
Contact point identification	Touch point: 10P	Average current	<200MA
Touch pressure	Zero pressure	Power dissipation	1W
Light transmittance	100% light transmittance	Maximum current	<350MA
Touch physical resolution	1000×1000	Resting current	<10mA
Touch mode	Finger, pen (non-capacitor, electromagnetic pen)	Response speed	≤8-20ms
Minimum identification point size	8mm×8mm	Port	USB2.0HID
Minimum contact detection	3mm	Scanning speed	50Frames/S
Surface durability	7H	Disturbed condition	No static interference, drift phenomenon
Temperature range/storage temperature	Operating temperature: 0°C-50°C—40°C-85°C	Support platform	Windows/xp\windows7\linux\android

## Product function

11.6 inch  
(Machine thickness: 180mm)  
Horizontal and vertical screens are universal

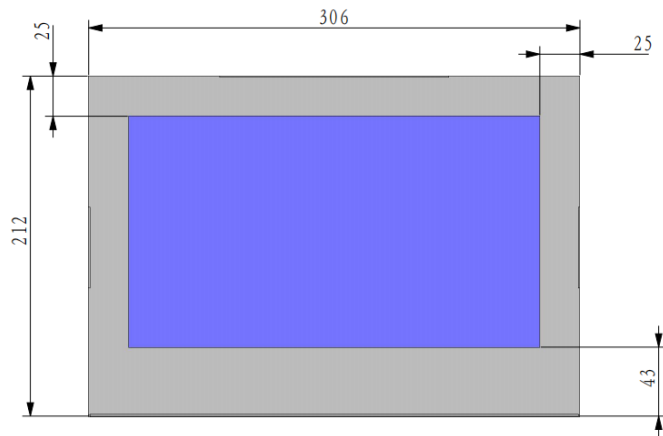

21.5 inch  
(Machine thickness: 310mm)  
Horizontal and vertical screens are universal

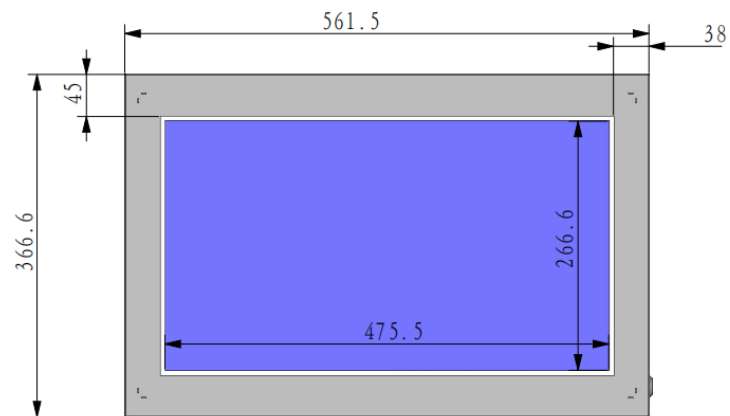

# Product display

32 inch  
(Machine thickness: 330mm)  
Horizontal and vertical screens are universal

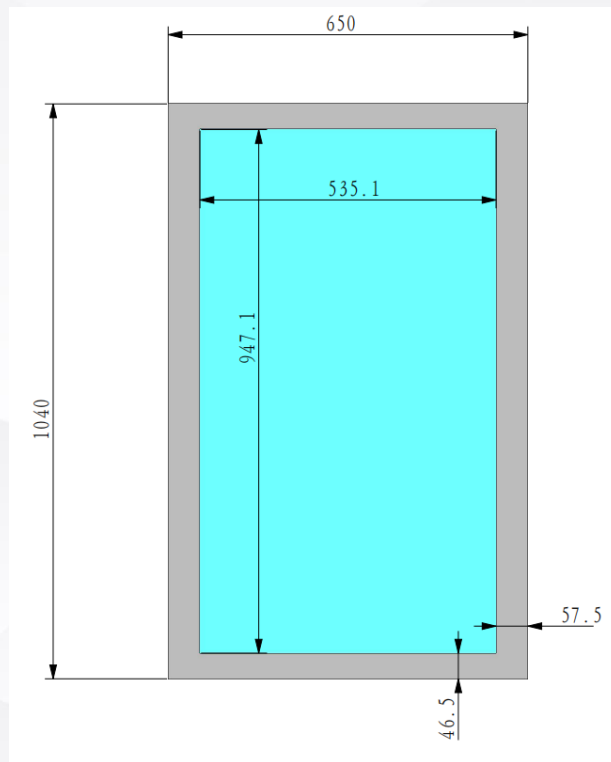
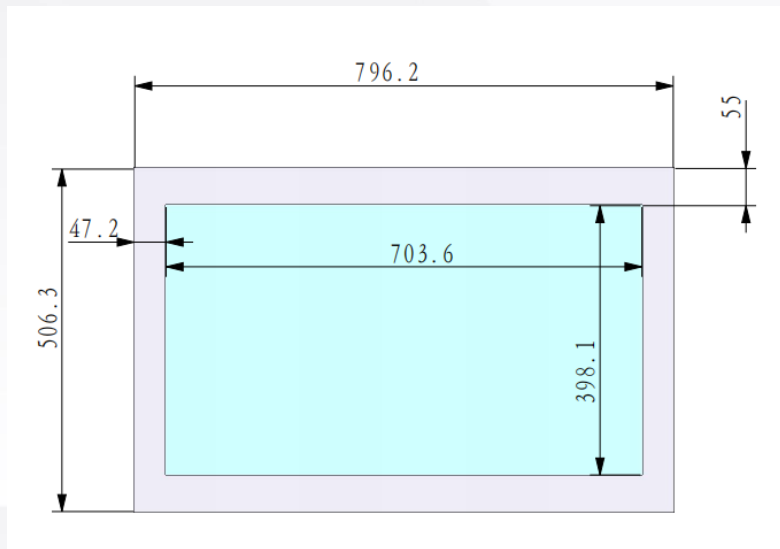

43 inch  
(Machine thickness: 330mm)  
Horizontal and vertical  
screens are universal

# Product display

55inch  
(thickness: 400mm)

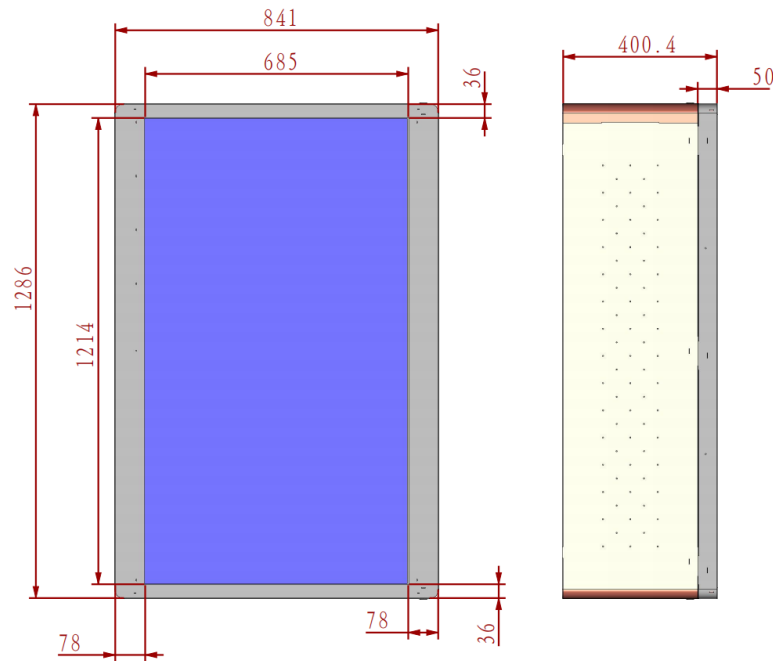

65inch  
(thickness: 420mm)

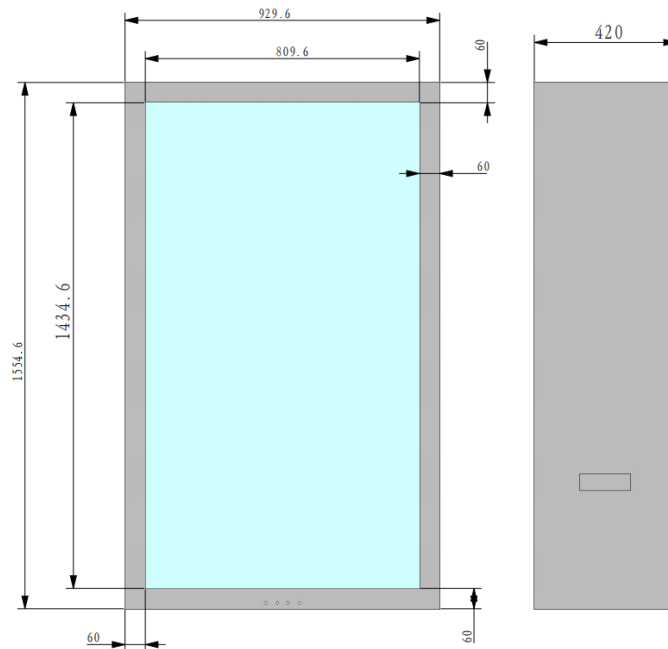

# Product display

75inch  
(thickness: 400mm)

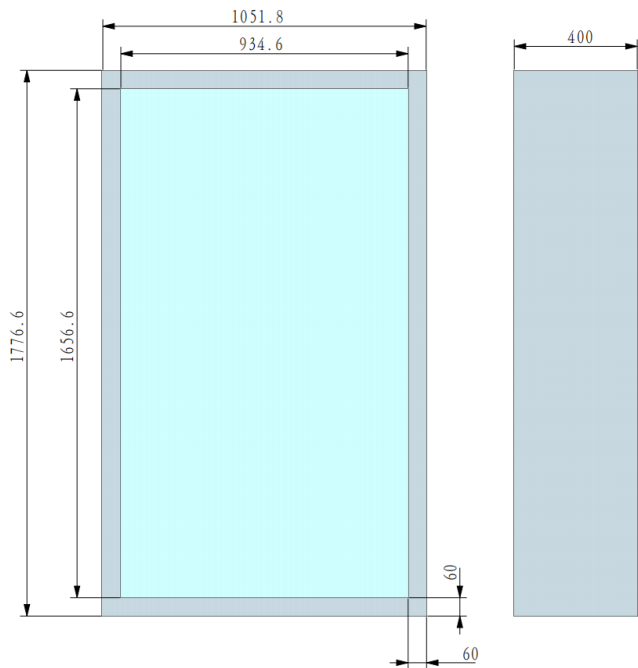

86inch  
(thickness: 600mm)

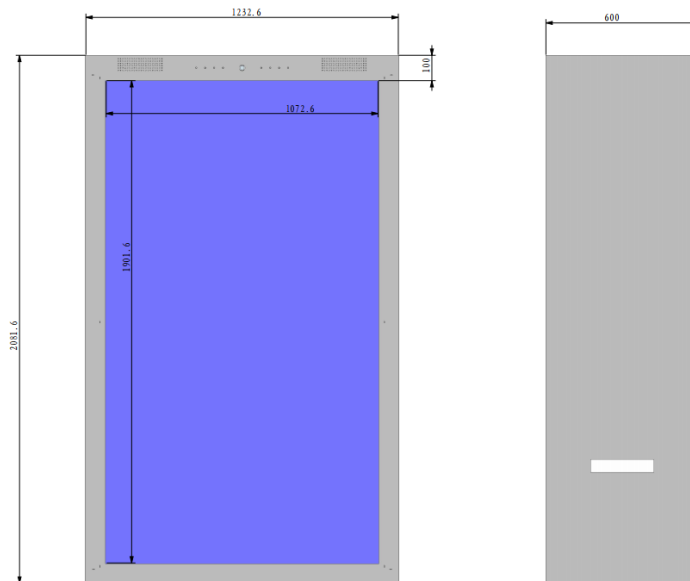



# Product display

86inch  
(thickness: 810mm)

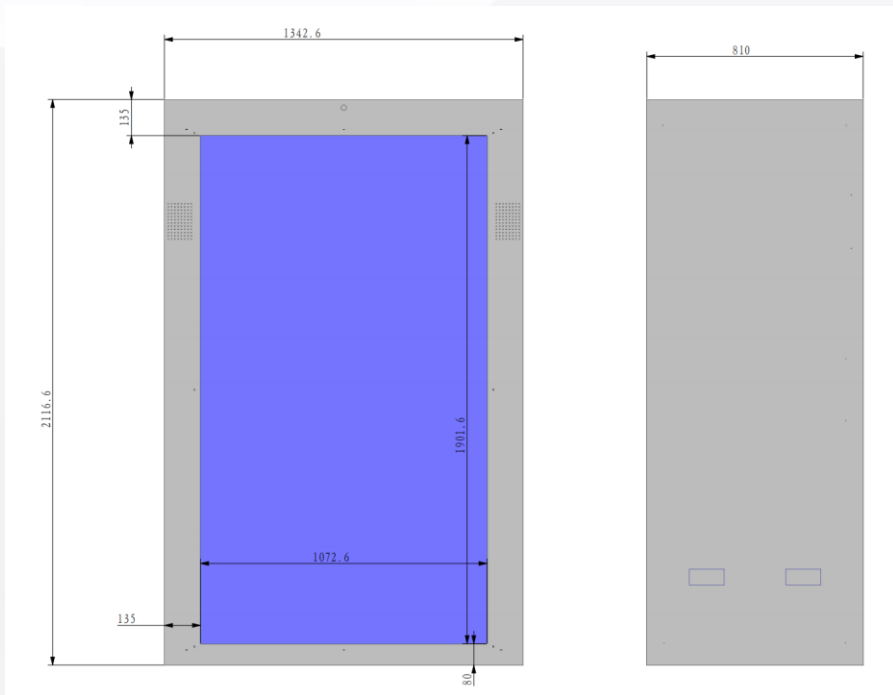

98inch  
(thickness: 620mm)

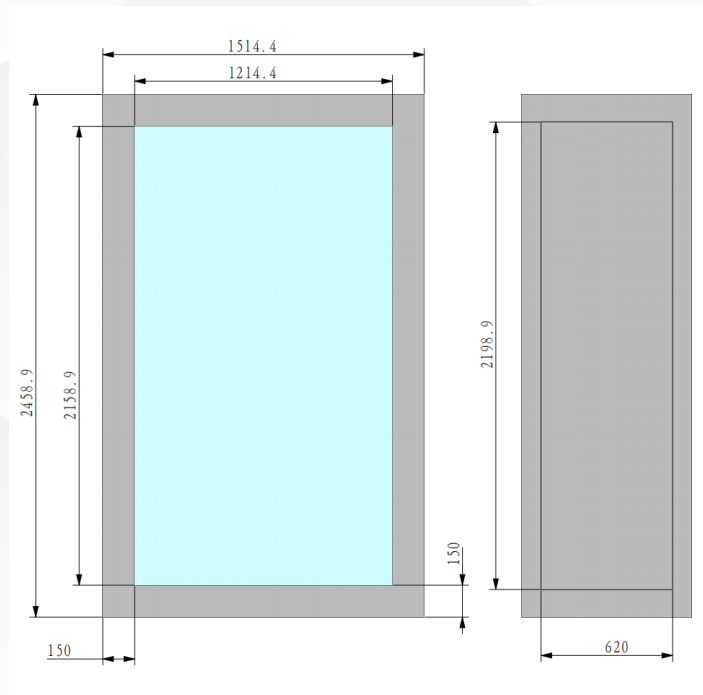



Global Traders: Operators of the Unconventional Inventory Liquidation Marketplace FreeWorldImports.com

---

## OTHER FREEWORLD INVENTORY LIQUIDATION SERVICES OFFERINGS | NON-AUCTION ITEMS

---

*Please click on the image or the associated hyperlink to learn more*

---



**[FWB – NON-AUCTION COMMODITIES WEBSTORE](#)**

---

309 Fellowship Road | East Gate Center | Suite 200 | Mt. Laurel | NJ 08054

Web-Presence: <http://freeworldbrand.com> | Liquidation Marketplace: <https://freeworldimports.com>

Commodities Webstore: <https://commodities.freeworldbrand.com/>

Phone/Fax: 609-256-9162 | Email: [bizdev@freeworldbrand.com](mailto:bizdev@freeworldbrand.com)



Global Traders: Operators of the Unconventional Inventory Liquidation Marketplace FreeWorldImports.com

---

*Please click on the image or the associated hyperlink to learn more*

---



**[SOURCE YOUR PRODUCTS HERE | DELIVERED DUTY PAID \(DDP\)](#)**

---

309 Fellowship Road | East Gate Center | Suite 200 | Mt. Laurel | NJ 08054

Web-Presence: <http://freeworldbrand.com> | Liquidation Marketplace: <https://freeworldimports.com>

Commodities Webstore: <https://commodities.freeworldbrand.com/>

Phone/Fax: 609-256-9162 | Email: [bizdev@freeworldbrand.com](mailto:bizdev@freeworldbrand.com)



**Global Traders:** Operators of the Unconventional Inventory Liquidation Marketplace [FreeWorldImports.com](https://freeworldimports.com)

---

*Please click on the image or the associated hyperlink to learn more*

---



## **DEPARTMENT STORES MIXED BUNDLES FOR BIG SAVINGS**

---

309 Fellowship Road | East Gate Center | Suite 200 | Mt. Laurel | NJ 08054

**Web-Presence:** <http://freeworldbrand.com> | **Liquidation Marketplace:** <https://freeworldimports.com>

Commodities Webstore: <https://commodities.freeworldbrand.com/>

**Phone/Fax:** 609-256-9162 | **Email:** [bizdev@freeworldbrand.com](mailto:bizdev@freeworldbrand.com)



**Global Traders:** Operators of the Unconventional Inventory Liquidation Marketplace [FreeWorldImports.com](https://freeworldimports.com)

---

*Please click on the image or the associated hyperlink to learn more*

---



**[FWI FEATURED SUPPLIERS](#)**

---

309 Fellowship Road | East Gate Center | Suite 200 | Mt. Laurel | NJ 08054

**Web-Presence:** <http://freeworldbrand.com> | **Liquidation Marketplace:** <https://freeworldimports.com>

Commodities Webstore: <https://commodities.freeworldbrand.com/>

**Phone/Fax:** 609-256-9162 | **Email:** [bizdev@freeworldbrand.com](mailto:bizdev@freeworldbrand.com)



Global Traders: Operators of the Unconventional Inventory Liquidation Marketplace FreeWorldImports.com

---

*Please click on the image or the associated hyperlink to learn more*

---



**[24 X 7 X 365 NON-AUCTION DEALS](#)**

---

309 Fellowship Road | East Gate Center | Suite 200 | Mt. Laurel | NJ 08054

Web-Presence: <http://freeworldbrand.com> | Liquidation Marketplace: <https://freeworldimports.com>

Commodities Webstore: <https://commodities.freeworldbrand.com/>

Phone/Fax: 609-256-9162 | Email: [bizdev@freeworldbrand.com](mailto:bizdev@freeworldbrand.com)





Global Traders: Operators of the Unconventional Inventory Liquidation Marketplace FreeWorldImports.com

*Please click on the image or the associated hyperlink to learn more*

**FWI LIQUIDATION MARKETPLACE AFFILIATE PROGRAM**

Become an **ONLINE INVENTORY LIQUIDATOR** using the FWI link based model which enable you to create links to any product within the FWI Marketplace. You have the ability to share these links with potential customers via email, social media and other digital mediums. You will **earn between two to five percent (2% - 5%) commission on the sales of products** which are sold based on your efforts. These links contains identifiers that will ensure that you receive compensation when a purchase is made on a linked item containing your identifier. There are no charges associated with this groundbreaking business opportunity, your participation will not cost you a dime, it is completely free of charge.

**Online Inventory Liquidation Marketplace**



**FREE WORLD IMPORTS**

**Buying Platform**  
<http://www.freeworldimports.com/>  
609-318-0570  
bizdev@freeworldimports.com

**ONLINE INVENTORY LIQUIDATOR REGISTRATION**

## **[FWI AFFILIATE PROGRAM](#)**

309 Fellowship Road | East Gate Center | Suite 200 | Mt. Laurel | NJ 08054

Web-Presence: <http://freeworldbrand.com> | Liquidation Marketplace: <https://freeworldimports.com>

Commodities Webstore: <https://commodities.freeworldbrand.com/>

Phone/Fax: 609-256-9162 | Email: [bizdev@freeworldbrand.com](mailto:bizdev@freeworldbrand.com)





Global Traders: Operators of the Unconventional Inventory Liquidation Marketplace [FreeWorldImports.com](https://freeworldimports.com)

---

*Please click on the image or the associated hyperlink to learn more*

---



## **[FWI SUPPLIER ENGAGEMENT](#)**

---

309 Fellowship Road | East Gate Center | Suite 200 | Mt. Laurel | NJ 08054

Web-Presence: <http://freeworldbrand.com> | Liquidation Marketplace: <https://freeworldimports.com>

Commodities Webstore: <https://commodities.freeworldbrand.com/>

Phone/Fax: 609-256-9162 | Email: [bizdev@freeworldbrand.com](mailto:bizdev@freeworldbrand.com)



Global Traders: Operators of the Unconventional Inventory Liquidation Marketplace FreeWorldImports.com

---

*Please click on the image or the associated hyperlink to learn more*

---

The advertisement features a woman in a white shirt and headset, smiling and gesturing with her hands. The background is white with a faint, large watermark of the letters "VPOS". At the top, there is a dark red banner with the "VPOS" logo on the left and the "HSRLCO SOLUTION" logo on the right. Below the banner, the text reads "DELIVERING VALUE TO CALL CENTERS AND BEYOND INTEGRATED VIRTUAL POINT OF SALE SOLUTION". At the bottom of the advertisement, the URL "www.sasapplication.com/webapplication" is displayed.

## **CLOUD BASED SOLUTIONS FOR FORWARD LOOKING ORGANIZATIONS**

---

309 Fellowship Road | East Gate Center | Suite 200 | Mt. Laurel | NJ 08054

Web-Presence: <http://freeworldbrand.com> | Liquidation Marketplace: <https://freeworldimports.com>

Commodities Webstore: <https://commodities.freeworldbrand.com/>

Phone/Fax: 609-256-9162 | Email: [bizdev@freeworldbrand.com](mailto:bizdev@freeworldbrand.com)



Global Traders: Operators of the Unconventional Inventory Liquidation Marketplace FreeWorldImports.com

---

*Please click on the image or the associated hyperlink to learn more*

---



## **PINK LABELED WOMEN'S URBAN APPAREL**

---

309 Fellowship Road | East Gate Center | Suite 200 | Mt. Laurel | NJ 08054

Web-Presence: <http://freeworldbrand.com> | Liquidation Marketplace: <https://freeworldimports.com>

Commodities Webstore: <https://commodities.freeworldbrand.com/>

Phone/Fax: 609-256-9162 | Email: [bizdev@freeworldbrand.com](mailto:bizdev@freeworldbrand.com)



Global Traders: Operators of the Unconventional Inventory Liquidation Marketplace FreeWorldImports.com

---

## **FOR MORE INFORMATION FREEWORLD LIQUIDATION SERVICES**

*A Service of FreeWorld Brand, LLC*



**Phone:** +1-609-256-9162

**Email:** [bizdev@freeworldimports.com](mailto:bizdev@freeworldimports.com)  
[bizdev@freeworldbrand.com](mailto:bizdev@freeworldbrand.com)

---

309 Fellowship Road | East Gate Center | Suite 200 | Mt. Laurel | NJ 08054

**Web-Presence:** <http://freeworldbrand.com> | **Liquidation Marketplace:** <https://freeworldimports.com>

Commodities Webstore: <https://commodities.freeworldbrand.com/>

**Phone/Fax:** 609-256-9162 | **Email:** [bizdev@freeworldbrand.com](mailto:bizdev@freeworldbrand.com)